

ARMOURPOST

L I M I T E D

'Grilla' Roller Shutter Specification



The 'Grilla' is a highly versatile and durable security product suitable for medium security commercial sites where see-through vision is a priority. The Tube & Link grille offers high visibility and can be used internally behind glass for shop displays, or as a stand-alone security barrier.

Provided with a 'Brick' or 'In Line' formation, utilising 13mm diameter tubes enclosing 8mm steel rods. Vertical lattice links create 56mm high openings enabling 75% transparency.

The shutters are supplied as standard with a manual override facility and a key switch control.

The shutters are available with single or three phase motors. The motor choice is normally made on the frequency of use of the shutter.

A single phase tube motor can fitted within the shutter barrel and this is the most commonly used motor. For a single phase shutter a 13amp 240V fused spur (by others) is required within 1 meter of the motor at motor height.

Optional Extras:

Battery Backup Facility

Key Fob Remote Control

Safety Edge Sensor to Bottom Rail

Bullet Locks For Additional Security

Group Controls For Several Shutters



Wide range of colour options

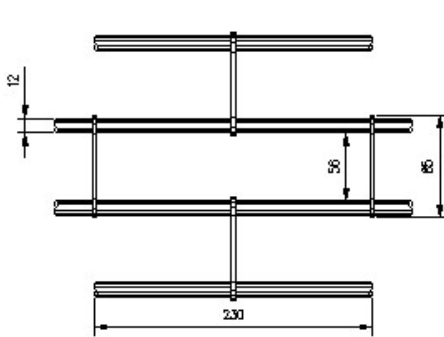

GRILLA BRICK BOND PATTERN

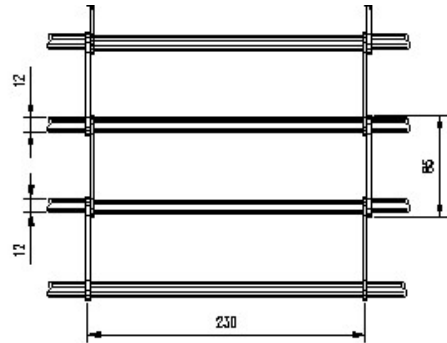

GRILLA IN LINE PATTERN